

1-3. How to Use the Manuals

The following paragraphs describe how each manual addresses the 5725A.

1-4. 5725A Getting Started Manual

Use this manual for basic getting started information, contacting Fluke, unpacking, and general specifications. This manual also provides setup and operation information for the 5725A Amplifier, descriptions of the 5725A front and rear-panel features, and information about setting up and powering up the 5725A. Please read this information before operating the amplifier.

1-5. 5725A Instruction Manual

Use the 5725A Instruction Manual for installing the 5725A, learning about its front and rear-panel features, and for all service-related topics such as maintenance, troubleshooting, parts lists, and schematics. (The 5725A Instruction Manual is the service and operator manual for the 5725A.)

Although the instruction manual also contains a section devoted to 5725A operating notes, once the 5725A is up and running you will find that the 5700A/5720A Operator Manual contains most of the information you need to operate the 5725A.

1-6. 5700A/5720A Series II Manual Set

The 5700A/5720A Series II Manual Set consists of a Getting Started Manual, an Operator Reference Guide, a Remote Programming Reference Guide and a CD-ROM containing an Operators Manual and Service Manual (in addition to all the other manuals provided in printed form).

1-7. 5700A/5720A Series II Operator Manual

The 5700A/5720A Series II Operator Manual contains the following information pertaining to the 5725A:

- Specifications for both the 5700A and 5725A (these same specifications are in this Instruction Manual)
- Cable connections to a UUT for amplified voltage and current
- Front panel (local) operation
- Remote control operation, IEEE-488 or RS-232
- Self calibration
- Fault codes (these appear on the 5700A Control Display, or are read from the 5700A in remote control operation)
- Calibration constant symbolic names
- Glossary of calibration-related terms

1-8. 5700A/5720A Series II Operator Reference Guide

The 5700A/5720A Series II Operator Reference Guide contains a summary of operating instructions from the Operator Manual. This booklet contains information needed to start up and operate the 5700A, but since the 5700A controls the 5725A, much of this information applies to the 5725A.

1-9. 5700A/5720A Series II Remote Programming Reference Guide

The 5700A/5720A Series II Remote Programming Reference Guide contains a summary of remote commands for the 5700A. It also contains information needed to determine system status using the status byte and registers. Remote commands and system status apply to a 5725A under control of the 5700A.

1-10. 5700A/5720A Series II Service Manual

The 5700A/5720A Series II Service Manual is a maintenance guide for the 5700A. The following 5725A topics are included in the 5700A/5720A Series II Service Manual:

- Specifications for both the 5700A and 5725A
- Full verification of the 5700A and 5725A (recommended every two years)
- Calibration of the 5700A and 5725A

1-11. Specifications

Specifications are valid after allowing a warm-up period of 30 minutes, or if the 5725A has been recently on, twice the time the 5725A has been turned off. For example, if the 5725A has been turned off for five minutes, the warm-up period is ten minutes.

Absolute uncertainty includes stability, temperature coefficient, linearity, line and load regulation, and traceability to external standards. You do not need to add anything to absolute uncertainty to determine the ratios between 5700A/5725A uncertainties and the uncertainties of your calibration workload.

Relative uncertainty specifications are provided for enhanced accuracy applications. These specifications apply when range constants are adjusted (see "Range Calibration" in the 5700A/5720A Series II Operator Manual). To calculate absolute uncertainty, you must combine the uncertainties of your external standards and techniques with relative uncertainty.

Secondary performance specifications and operating characteristics are included in the uncertainty specifications. They are also provided separately for special calibration requirements such as stability or linearity testing.

The specifications for the 5725A are provided in the following tables as subsets to the 5700A and 5720A Series II Calibrators.

1-12. DC Voltage Specifications

Table 1-1. 5720A Series II DC Voltage Specifications: 99 % and 95 % Confidence Levels

5720A
99%

99 % Confidence Level

Range	Resolution	Absolute Uncertainty ± 5 °C from calibration temperature For fields strengths >1 V/m but ≤3 V/m, add 0.01% of range.				Relative Uncertainty ± 1 °C	
		24 Hours	90 Days	180 Days	1 Year	24 Hours	90 Days
		± (ppm output + μV)				± (ppm output + μV)	
220 mV	10 nV	5 + 0.5	7 + 0.5	8 + 0.5	9 + 0.5	2 + 0.4	2.5 + 0.4
2.2 V	100 nV	3.5 + 0.8	4 + 0.8	4.5 + 0.8	6 + 0.8	2 + 0.8	2.5 + 0.8
11 V	1 μV	2.5 + 3	3 + 3	3.5 + 3	4 + 3	1 + 3	1.5 + 3
22 V	1 μV	2.5 + 5	3 + 5	3.5 + 5	4 + 5	1 + 5	1.5 + 5
220 V	10 μV	3.5 + 50	4 + 50	5 + 50	6 + 50	2 + 50	2.5 + 50
1100 V	100 μV	5 + 500	6 + 500	7 + 500	8 + 500	2.5 + 400	3 + 400

5720A
95%

95% Confidence Level

Range	Resolution	Absolute Uncertainty ± 5 °C from calibration temperature For fields strengths >1 V/m but ≤3 V/m, add 0.01 % of range.				Relative Uncertainty ± 1 °C	
		24 Hours	90 Days	180 Days	1 Year	24 Hours	90 Days
		± (ppm output + μV)				± (ppm output + μV)	
220 mV	10 nV	4 + 0.4	6 + 0.4	6.5 + 0.4	7.5 + 0.4	1.6 + 0.4	2 + 0.4
2.2 V	100 nV	3 + 0.7	3.5 + 0.7	4 + 0.7	5 + 0.7	1.6 + 0.7	2 + 0.7
11 V	1 μV	2 + 2.5	2.5 + 2.5	3 + 2.5	3.5 + 2.5	0.8 + 2.5	1.2 + 2.5
22 V	1 μV	2 + 4	2.5 + 4	3 + 4	3.5 + 4	0.8 + 4	1.2 + 4
220 V	10 μV	3 + 40	3.5 + 40	4 + 40	5 + 40	1.6 + 40	2 + 40
1100 V	100 μV	4 + 400	4.5 + 400	6 + 400	6.5 + 400	2 + 400	2.4 + 400

Table 1-2. 5700A Series II DC Voltage Specifications: 99 % and 95 % Confidence Levels

**5700A
99%****99 % Confidence Level**

Range	Resolution	Absolute Uncertainty ± 5 °C from calibration temperature For fields strengths >1 V/m but ≤3 V/m, add 0.01 % of range.				Relative Uncertainty ± 1 °C	
		24 Hours	90 Days	180 Days	1 Year	24 Hours	90 Days
		± (ppm output + μV)				± (ppm output + μV)	
220 mV	10 nV	6.5 + .75	7 + .75	8 + .75	9 + .8	2.5 + .5	4 + .5
2.2 V	100 nV	3.5 + 1.2	6 + 1.2	7 + 1.2	8 + 1.2	2.5 + 1.2	4 + 1.2
11 V	1 μV	3.5 + 3	5 + 4	7 + 4	8 + 4	1.5 + 3	3.5 + 4
22 V	1 μV	3.5 + 6	5 + 8	7 + 8	8 + 8	1.5 + 6	3.5 + 8
220 V	10 μV	5 + 100	6 + 100	8 + 100	9 + 100	2.5 + 100	4 + 100
1100 V	100 μV	7 + 600	8 + 600	10 + 600	11 + 600	3 + 600	1.5 + 600

**5700A
95%****95 % Confidence Level**

Range	Resolution	Absolute Uncertainty ± 5 °C from calibration temperature For fields strengths >1 V/m but ≤3 V/m, add 0.01 % of range.				Relative Uncertainty ± 1 °C	
		24 Hours	90 Days	180 Days	1 Year	24 Hours	90 Days
		± (ppm output + μV)				± (ppm output + μV)	
220 mV	10 nV	5.5 + 0.6	6 + 0.6	7 + 0.6	8 + 0.6	2 + 0.4	3.5 + 0.4
2.2 V	100 nV	3.5 + 1	5 + 1	6 + 1	7 + 1	2 + 1	3.5 + 1
11 V	1 mV	3 + 3.5	4 + 3.5	6 + 3.5	7 + 3.5	1.2 + 3	3 + 3.5
22 V	1 mV	3 + 6.5	4 + 6.5	6 + 6.5	7 + 6.5	1.2 + 6	3 + 7
220 V	10 mV	4 + 80	5 + 80	7 + 80	8 + 80	2 + 80	3.5 + 80
1100 V	100 mV	6 + 500	7 + 500	8 + 500	9 + 500	2.4 + 500	4 + 500

Table 1-3. DC Voltage Secondary Performance Specifications and Operating Characteristics

Range	Stability [Note 1] ± 1 °C 24 Hours ± (ppm output + μV)	Temperature Coefficient Adder [Note 2]		Linearity ± 1 °C ± (ppm output + μV)	Noise	
		10 °-40 °C	0 °-10 °C and 40°-50 °C		Bandwidth 0.1-10 Hz	Bandwidth 10 Hz-10 kHz
		± (ppm output + μV)/°C			pk-pk	RMS
						μV
220 mV	0.3 + 0.3	0.4 + 0.1	1.5 + 0.5	1 + 0.2	0.15 + 0.1	5
2.2 V	0.3 + 1	0.3 + 0.1	1.5 + 2	1 + 0.6	0.15 + 0.4	15
11 V	0.3 + 2.5	0.15 + 0.2	1 + 1.5	0.3 + 2	0.15 + 2	50
22 V	0.4 + 5	0.2 + 0.4	1.5 + 3	0.3 + 4	0.15 + 4	50
220 V	0.5 + 40	0.3 + 5	1.5 + 40	1 + 40	0.15 + 60	150
1100 V	0.5 + 200	0.5 + 10	3 + 200	1 + 200	0.15 + 300	500

Notes:

1. Stability specifications are included in the Absolute Uncertainty values in the primary specification tables.
2. Temperature coefficient is an adder to uncertainty specifications that does *not* apply unless operating more than ±5 °C from calibration temperature.

Minimum output: 0 V for all ranges, except 100 V for 1100 V range

Maximum load: 50 mA for 2.2 V through 220 V ranges; 20 mA for 1100 V range; 50 Ω output impedance on 220 mV range; all ranges <1000 pF, >25 Ω

Load regulation: <(0.2 ppm of output + 0.1ppm of range), full load to no load

Line regulation: <0.1 ppm change, ± 10 % of selected nominal line

Settling time: 3 seconds to full accuracy; + 1 second for range or polarity change; + 1 second for 1100 V range

Overshoot: <5 %

Common mode rejection: 140 dB, DC to 400 Hz

Remote sensing: Available 0 V to ±1100 V, on 2.2 V through 1100 V ranges

1-13. AC Voltage Specifications

Table 1-4. 5720A Series II AC Voltage Specifications: 99 % Confidence Level

5720A
99%

99 % Confidence Level

Range	Resolution	Frequency	Absolute Uncertainty ± 5 °C from calibration temperature				Relative Uncertainty ± 1 °C	
			24 Hours	90 Days	180 Days	1 Year	24 Hours	90 Days
			± (ppm output + μV)					
2.2 mV	1 nV	10 - 20	250 + 5	270 + 5	290 + 5	300 + 5	250 + 5	270 + 5
		20 - 40	100 + 5	105 + 5	110 + 5	115 + 5	100 + 5	105 + 5
		40 - 20 k	85 + 5	90 + 5	95 + 5	100 + 5	85 + 5	95 + 5
		20 k - 50 k	220 + 5	230 + 5	240 + 5	250 + 5	200 + 6	220 + 6
		50 k - 100 k	500 + 6	540 + 6	570 + 6	600 + 6	350 + 12	400 + 12
		100 k - 300 k	1000 + 12	1200 + 12	1250 + 12	1300 + 12	800 + 25	1000 + 25
		300 k - 500 k	1400 + 25	1500 + 25	1600 + 25	1700 + 25	2700 + 25	3000 + 25
500 k - 1 M	2900 + 25	3100 + 25	3250 + 25	3400 + 25				
22 mV	10 nV	10 - 20	250 + 5	270 + 5	290 + 5	300 + 5	250 + 5	270 + 5
		20 - 40	100 + 5	105 + 5	110 + 5	115 + 5	100 + 5	105 + 5
		40 - 20 k	85 + 5	90 + 5	95 + 5	100 + 5	85 + 5	95 + 5
		20 k - 50 k	220 + 5	230 + 5	240 + 5	250 + 5	200 + 6	220 + 6
		50 k - 100 k	500 + 6	540 + 6	570 + 6	600 + 6	350 + 12	400 + 12
		100 k - 300 k	1000 + 12	1200 + 12	1250 + 12	1300 + 12	800 + 25	1000 + 25
		300 k - 500 k	1400 + 25	1500 + 25	1600 + 25	1700 + 25	2700 + 25	3000 + 25
500 k - 1 M	2900 + 25	3100 + 25	3250 + 25	3400 + 25				
220 mV	100 nV	10 - 20	250 + 15	270 + 15	290 + 15	300 + 15	250 + 15	270 + 15
		20 - 40	100 + 8	105 + 8	110 + 8	115 + 8	100 + 8	105 + 8
		40 - 20 k	85 + 8	90 + 8	95 + 8	100 + 8	85 + 8	95 + 8
		20 k - 50 k	220 + 8	230 + 8	240 + 8	250 + 8	200 + 20	220 + 20
		50 k - 100 k	500 + 20	540 + 20	570 + 20	600 + 20	350 + 25	400 + 25
		100 k - 300 k	850 + 25	900 + 25	1000 + 25	1100 + 25	800 + 30	1000 + 30
		300 k - 500 k	1400 + 30	1500 + 30	1600 + 30	1700 + 30	2600 + 60	2800 + 60
500 k - 1 M	2700 + 60	2900 + 60	3100 + 60	3300 + 60				
2.2 V	1 mV	10 - 20	250 + 50	270 + 50	290 + 50	300 + 50	250 + 50	270 + 50
		20 - 40	95 + 20	100 + 20	105 + 20	110 + 20	95 + 20	100 + 20
		40 - 20 k	45 + 10	47 + 10	50 + 10	52 + 10	30 + 10	40 + 10
		20 k - 50 k	80 + 12	85 + 12	87 + 12	90 + 12	70 + 12	75 + 12
		50 k - 100 k	120 + 40	125 + 40	127 + 40	130 + 40	100 + 40	105 + 40
		100 k - 300 k	380 + 100	420 + 100	460 + 100	500 + 100	270 + 100	290 + 100
		300 k - 500 k	1000 + 250	1100 + 250	1150 + 250	1200 + 250	900 + 250	1000 + 250
500 k - 1 M	1600 + 400	1800 + 600	1900 + 400	2000 + 400	1200 + 400	1300 + 400		
22 V	10 mV	10 - 20	250 + 500	270 + 500	290 + 500	300 + 500	250 + 500	270 + 500
		20 - 40	95 + 200	100 + 200	105 + 200	110 + 200	95 + 200	100 + 200
		40 - 20 k	45 + 70	47 + 70	50 + 70	52 + 70	30 + 70	40 + 70
		20 k - 50 k	80 + 120	85 + 120	87 + 120	90 + 120	70 + 120	75 + 120
		50 k - 100 k	110 + 250	115 + 250	117 + 250	120 + 250	100 + 250	105 + 250
		100 k - 300 k	300 + 800	310 + 800	320 + 800	325 + 800	270 + 800	290 + 800
		300 k - 500 k	1000 + 2500	1100 + 2500	1150 + 2500	1200 + 2500	900 + 2500	1000 + 2500
500 k - 1 M	1500 + 4000	1600 + 4000	1700 + 4000	1800 + 4000	1300 + 4000	1400 + 4000		
220 V [Note 2]	100 mV	10 - 20	250 + 5	270 + 5	290 + 5	300 + 5	250 + 5	270 + 5
		20 - 40	95 + 2	100 + 2	105 + 2	110 + 2	95 + 2	100 + 2
		40 - 20 k	57 + 0.7	60 + 0.7	62 + 0.7	65 + 0.7	45 + 0.7	50 + 0.7
		20 k - 50 k	90 + 1.2	95 + 1.2	97 + 1.2	100 + 1.2	75 + 1.2	80 + 1.2
		50 k - 100 k	160 + 3	170 + 3	175 + 3	180 + 3	140 + 3	150 + 3
		100 k - 300 k	900 + 20	1000 + 20	1050 + 20	1100 + 20	600 + 20	700 + 20
		300 k - 500 k	5000 + 50	5200 + 50	5300 + 50	5400 + 50	4500 + 50	4700 + 50
500 k - 1 M	8000 + 100	9000 + 100	9500 + 100	10,000 + 100	8000 + 100	8500 + 100		
1100 V	1 mV [Note 1]	15 - 50	300 + 20	320 + 20	340 + 20	360 + 20	300 + 20	320 + 20
		50 - 1 k	70 + 4	75 + 4	80 + 4	85 + 4	50 + 4	55 + 4
5725A Amplifier:								
1100 V	1 mV	40 - 1 k	75 + 4	80 + 4	85 + 4	90 + 4	50 + 4	55 + 4
		1 k - 20 k	105 + 6	125 + 6	135 + 6	165 + 6	85 + 6	105 + 6
		20 k - 30 k	230 + 11	360 + 11	440 + 11	600 + 11	160 + 11	320 + 11
750 V	1 mV	30 k - 50 k	230 + 11	360 + 11	440 + 11	600 + 11	160 + 11	320 + 11
		50 k - 100k	600 + 45	1300 + 45	1600 + 45	2300 + 45	380 + 45	1200 + 45

Notes: 1. Maximum output 250V from 15-50 Hz.
2. See Volt-Hertz capability in Figure 1-2.

Table 1-5. 5720A Series II AC Voltage Specifications: 95 % Confidence Level

5720A
95%

95 % Confidence Level

Range	Resolution	Frequency	Absolute Uncertainty ± 5 °C from calibration temperature				Relative Uncertainty ± 1 °C	
			24 Hours	90 Days	180 Days	1 Year	24 Hours	90 Days
			± (ppm output + μV)				± (ppm output + μV)	
2.2 mV	1 nV	10 - 20	200 + 4	220 + 4	230 + 4	240 + 4	200 + 4	220 + 4
		20 - 40	80 + 4	85 + 4	87 + 4	90 + 4	80 + 4	85 + 4
		40 - 20 k	70 + 4	75 + 4	77 + 4	80 + 4	50 + 4	55 + 4
		20 k - 50 k	170 + 4	180 + 4	190 + 4	200 + 4	70 + 4	80 + 4
		50 k - 100 k	400 + 5	460 + 5	480 + 5	500 + 5	160 + 5	180 + 5
		100 k - 300 k	300 + 10	900 + 10	1000 + 10	1050 + 10	280 + 10	320 + 10
		300 k - 500 k	1100 + 20	1200 + 20	1300 + 20	1400 + 20	650 + 20	800 + 20
500 k - 1 M	2400 + 20	2500 + 20	2600 + 20	2700 + 20	2100 + 20	2400 + 20		
22 mV	10 nV	10 - 20	200 + 4	220 + 4	230 + 4	240 + 4	200 + 4	220 + 4
		20 - 40	80 + 4	85 + 4	87 + 4	90 + 4	80 + 4	85 + 4
		40 - 20 k	70 + 4	75 + 4	77 + 4	80 + 4	50 + 4	55 + 4
		20 k - 50 k	170 + 4	180 + 4	190 + 4	200 + 4	70 + 4	80 + 4
		50 k - 100 k	400 + 5	460 + 5	480 + 5	500 + 5	160 + 5	180 + 5
		100 k - 300 k	300 + 10	900 + 10	1000 + 10	1050 + 10	280 + 10	320 + 10
		300 k - 500 k	1100 + 20	1200 + 20	1300 + 20	1400 + 20	650 + 20	800 + 20
500 k - 1 M	2400 + 20	2500 + 20	2600 + 20	2700 + 20	2100 + 20	2400 + 20		
220 mV	100 nV	10 - 20	200 + 12	220 + 12	230 + 12	240 + 12	200 + 12	220 + 12
		20 - 40	80 + 7	85 + 7	87 + 7	90 + 7	80 + 7	85 + 7
		40 - 20 k	70 + 7	75 + 7	77 + 7	80 + 7	50 + 7	55 + 7
		20 k - 50 k	170 + 7	180 + 7	190 + 7	200 + 7	70 + 7	80 + 7
		50 k - 100 k	400 + 17	420 + 17	440 + 17	460 + 17	160 + 17	180 + 17
		100 k - 300 k	700 + 20	750 + 20	800 + 20	900 + 20	280 + 20	320 + 20
		300 k - 500 k	1100 + 25	1200 + 25	1300 + 25	1400 + 25	650 + 25	800 + 25
500 k - 1 M	2400 + 45	2500 + 45	2600 + 45	2700 + 45	2100 + 45	2400 + 45		
2.2 V	1 mV	10 - 20	200 + 40	220 + 40	230 + 40	240 + 40	200 + 40	220 + 40
		20 - 40	75 + 15	80 + 15	85 + 15	90 + 15	75 + 15	80 + 15
		40 - 20 k	37 + 8	40 + 8	42 + 8	45 + 8	25 + 8	35 + 8
		20 k - 50 k	65 + 10	70 + 10	73 + 10	75 + 10	55 + 10	60 + 10
		50 k - 100 k	100 + 30	105 + 30	107 + 30	110 + 30	80 + 30	85 + 30
		100 k - 300 k	300 + 80	340 + 80	380 + 80	420 + 80	230 + 80	250 + 80
		300 k - 500 k	800 + 200	900 + 200	950 + 200	1000 + 200	700 + 200	800 + 200
500 k - 1 M	1300 + 300	1500 + 300	1600 + 300	1700 + 300	1000 + 300	1100 + 300		
22V	10 mV	10 - 20	200 + 400	220 + 400	230 + 400	240 + 400	200 + 400	220 + 400
		20 - 40	75 + 150	80 + 150	85 + 150	90 + 150	75 + 150	80 + 150
		40 - 20k	37 + 50	40 + 50	42 + 50	45 + 50	25 + 50	35 + 50
		20k - 50k	65 + 100	70 + 100	73 + 100	75 + 100	55 + 100	60 + 100
		50k - 100k	90 + 200	95 + 200	97 + 200	100 + 200	80 + 200	85 + 200
		100k - 300k	250 + 600	260 + 600	270 + 600	275 + 600	250 + 600	270 + 600
		300k - 500k	800 + 2000	900 + 2000	900 + 2000	1000 + 2000	700 + 2000	800 + 2000
500k - 1M	1200 + 3200	1300 + 3200	1400 + 3200	1500 + 3200	1100 + 3200	1200 + 3200		
			± (ppm output + mV)				± (ppm output + mV)	
220 V [Note 2]	100 mV	10 - 20	200 + 4	220 + 4	230 + 4	240 + 4	200 + 4	220 + 4
		20 - 40	75 + 1.5	80 + 1.5	85 + 1.5	90 + 1.5	75 + 1.5	80 + 1.5
		40 - 20 k	45 + 0.6	47 + 0.6	50 + 0.6	52 + 0.6	35 + 0.6	40 + 0.6
		20 k - 50 k	70 + 1	75 + 1	77 + 1	80 + 1	60 + 1	65 + 1
		50 k - 100 k	120 + 2.5	130 + 2.5	140 + 2.5	150 + 2.5	110 + 2.5	120 + 2.5
		100 k - 300 k	700 + 16	800 + 16	850 + 16	900 + 16	500 + 16	600 + 16
		300 k - 500 k	4000 + 40	4200 + 40	4300 + 40	4400 + 40	3600 + 40	3800 + 40
500 k - 1 M	6000 + 80	7000 + 80	7500 + 80	8000 + 80	6500 + 80	7000 + 80		
1100 V	1 mV [Note 1]	15 - 50	240 + 16	260 + 16	280 + 16	300 + 16	240 + 16	260 + 16
		50 - 1 k	55 + 3.5	60 + 3.5	65 + 3.5	70 + 3.5	40 + 3.5	45 + 3.5
5725A Amplifier:								
1100 V	1 mV	40 - 1 k	75 + 4	80 + 4	85 + 4	90 + 4	50 + 4	55 + 4
		1 k - 20 k	105 + 6	125 + 6	135 + 6	165 + 6	85 + 6	105 + 6
		20 k - 30 k	230 + 11	360 + 11	440 + 11	600 + 11	160 + 11	320 + 11
		30 k - 50 k	230 + 11	360 + 11	440 + 11	600 + 11	160 + 11	320 + 11
750 V		50 k - 100 k	600 + 45	1300 + 45	1600 + 45	2300 + 45	380 + 45	1200 + 45

Notes: 1. Maximum output 250V from 15-50 Hz.
2. See Volt-Hertz capability in Figure 1-2.

Table 1-6. 5700A Series II AC Voltage Specifications: 99 % Confidence Level

5700A 99%			99 % Confidence Level				Relative Uncertainty ± 1 °C	
Range	Resolution	Frequency	Absolute Uncertainty ± 5 °C from calibration temperature				24 Hours	90 Days
			24 Hours	90 Days	180 Days	1 Year	± (ppm output + μV)	± (ppm output + μV)
			± (ppm output + μV)				± (ppm output + mV)	
2.2 mV	1 nV	10 - 20	500 + 5	550 + 5	600 + 5	600 + 5	500 + 5	550 + 5
		20 - 40	200 + 5	220 + 5	230 + 5	240 + 5	200 + 5	220 + 5
		40 - 20 k	100 + 5	110 + 5	120 + 5	120 + 5	60 + 5	65 + 5
		20 k - 50 k	340 + 5	370 + 5	390 + 5	410 + 5	100 + 5	110 + 5
		50 k - 100 k	800 + 8	900 + 8	950 + 8	950 + 8	220 + 8	240 + 8
		100 k - 300 k	1100 + 15	1200 + 15	1300 + 15	1300 + 15	400 + 15	440 + 15
		300 k - 500 k	1500 + 30	1700 + 30	1700 + 30	1800 + 30	1000 + 30	1100 + 30
500 k - 1 M	4000 + 40	4400 + 40	4700 + 40	4800 + 40	400 + 30	4400 + 30		
22 mV	10 nV	10 - 20	500 + 6	550 + 6	600 + 6	600 + 6	500 + 6	550 + 6
		20 - 40	200 + 6	220 + 6	230 + 6	240 + 6	200 + 6	220 + 6
		40 - 20 k	100 + 6	110 + 6	120 + 6	120 + 6	60 + 6	65 + 6
		20 k - 50 k	340 + 6	370 + 6	390 + 6	410 + 6	100 + 6	110 + 6
		50 k - 100 k	800 + 8	900 + 8	950 + 8	950 + 8	220 + 8	240 + 8
		100 k - 300 k	1100 + 15	1200 + 15	1300 + 15	1300 + 15	400 + 15	440 + 15
		300 k - 500 k	1500 + 30	1700 + 30	1700 + 30	1800 + 30	1000 + 30	1100 + 30
500 k - 1 M	4000 + 40	4400 + 40	4700 + 40	4800 + 40	4000 + 30	4400 + 30		
220 mV	100 nV	10 - 20	500 + 16	550 + 16	600 + 16	600 + 16	500 + 16	550 + 16
		20 - 40	200 + 10	220 + 10	230 + 10	240 + 10	200 + 10	220 + 10
		40 - 20 k	95 + 10	100 + 10	110 + 10	110 + 10	60 + 10	65 + 10
		20 k - 50 k	300 + 10	330 + 10	350 + 10	360 + 10	100 + 10	110 + 10
		50 k - 100 k	750 + 30	800 + 30	850 + 30	900 + 30	220 + 30	240 + 30
		100 k - 300 k	940 + 30	1000 + 30	1100 + 30	1100 + 30	400 + 30	440 + 30
		300 k - 500 k	1500 + 40	1700 + 40	1700 + 40	1800 + 40	1000 + 40	1100 + 40
500 k - 1 M	3000 + 100	3300 + 100	3500 + 100	3600 + 100	3000 + 100	3300 + 100		
2.2 V	1 mV	10 - 20	500 + 100	550 + 100	600 + 100	600 + 100	500 + 100	550 + 100
		20 - 40	150 + 30	170 + 30	170 + 30	180 + 30	150 + 30	170 + 30
		40 - 20 k	70 + 7	75 + 7	80 + 7	85 + 7	40 + 7	45 + 7
		20 k - 50 k	120 + 20	130 + 20	140 + 20	140 + 20	100 + 20	110 + 20
		50 k - 100 k	230 + 80	250 + 80	270 + 80	280 + 80	200 + 80	220 + 80
		100 k - 300 k	400 + 150	440 + 150	470 + 150	480 + 150	400 + 150	440 + 150
		300 k - 500 k	1000 + 400	1100 + 400	1200 + 400	1200 + 400	1000 + 400	1100 + 400
500 k - 1 M	2000 + 1000	2200 + 1000	2300 + 1000	2400 + 1000	2000 + 1000	2200 + 1000		
22 V	10 mV	10 - 20	500 + 1000	550 + 1000	600 + 1000	600 + 1000	500 + 1000	550 + 1000
		20 - 40	150 + 300	170 + 300	170 + 300	180 + 300	150 + 300	170 + 300
		40 - 20 k	70 + 70	75 + 70	80 + 70	85 + 70	40 + 70	45 + 70
		20 k - 50 k	120 + 200	130 + 200	140 + 200	140 + 200	100 + 200	110 + 200
		50 k - 100 k	230 + 400	250 + 400	270 + 400	280 + 400	200 + 400	220 + 400
		100 k - 300 k	500 + 1700	550 + 1700	550 + 1700	600 + 1700	500 + 1700	550 + 1700
		300 k - 500 k	1200 + 5000	1300 + 5000	1300 + 5000	1400 + 5000	1200 + 5000	1300 + 5000
500 k - 1 M	2600 + 9000	2800 + 9000	2900 + 9000	3000 + 9000	2600 + 9000	2800 + 9000		
220 V [Note 2]	100 mV	10 - 20	500 + 10	550 + 10	600 + 10	600 + 10	500 + 10	550 + 10
		20 - 40	150 + 3	170 + 3	170 + 3	180 + 3	150 + 3	170 + 3
		40 - 20 k	75 + 1	80 + 1	85 + 1	90 + 1	45 + 1	50 + 1
		20 k - 50 k	200 + 4	220 + 4	240 + 4	250 + 4	100 + 1	110 + 1
		50 k - 100 k	500 + 10	550 + 10	600 + 10	600 + 10	300 + 10	330 + 10
		100 k - 300 k	1500 + 110	1500 + 110	1600 + 110	1600 + 110	1500 + 110	1500 + 110
		300 k - 500 k	5000 + 110	5200 + 110	5300 + 110	5400 + 110	5000 + 110	5200 + 110
500 k - 1 M	12,000 + 220	12,500 + 220	12,500 + 220	13,000 + 220	12,000 + 220	12,000 + 220		
1100 V	1 mV [Note 1]	15 - 50	400 + 20	420 + 20	440 + 20	460 + 20	400 + 20	420 + 20
		50 - 1 k	75 + 4	80 + 4	85 + 4	90 + 4	50 + 4	55 + 4
5725A Amplifier:								
1100 V	1 mV	40 - 1 k	75 + 4	80 + 4	85 + 4	90 + 4	50 + 4	55 + 4
		1 k - 20 k	105 + 6	125 + 6	135 + 6	165 + 6	85 + 6	105 + 6
		20 k - 30 k	230 + 11	360 + 11	440 + 11	600 + 11	160 + 11	320 + 11
750 V		30 k - 50 k	230 + 11	360 + 11	440 + 11	600 + 11	160 + 11	320 + 11
		50 k - 100 k	600 + 45	1300 + 45	1600 + 45	2300 + 45	380 + 45	1200 + 45

Notes: 1. Maximum output 250V from 15-50 Hz.
2. See Volt-Hertz capability in Figure 1-2.

Table 1-7. 5700A Series II AC Voltage Specifications: 95 % Confidence Level

5700A
95%

95% Confidence Level

Range	Resolution	Frequency	Absolute Uncertainty ± 5 °C from calibration temperature				Relative Uncertainty ± 1 °C	
			24 Hours	90 Days	180 Days	1 Year	24 Hours	90 Days
			± (ppm output + μV)				± (ppm output + μV)	
2.2 mV	1 nV	10 - 20	400 + 4.5	500 + 4.5	530 + 4.5	550 + 4.5	400 + 4.5	500 + 4.5
		20 - 40	170 + 4.5	190 + 4.5	200 + 4.5	210 + 4.5	170 + 4.5	190 + 4.5
		40 - 20 k	85 + 4.5	95 + 4.5	100 + 4.5	105 + 4.5	55 + 4.5	60 + 4.5
		20 k - 50 k	300 + 4.5	330 + 4.5	350 + 4.5	370 + 4.5	90 + 4.5	100 + 4.5
		50 k - 100 k	700 + 7	750 + 7	800 + 7	850 + 7	210 + 7	230 + 7
		100 k - 300 k	900 + 13	1000 + 13	1050 + 13	1100 + 13	380 + 13	420 + 13
		300 k - 500 k	1300 + 25	1500 + 25	1600 + 25	1700 + 25	900 + 25	1000 + 25
500 k - 1 M	2800 + 25	3100 + 25	3300 + 25	3400 + 25	2900 + 25	3200 + 25		
22 mV	10 nV	10 - 20	400 + 5	500 + 5	530 + 5	550 + 5	400 + 5	500 + 5
		20 - 40	170 + 5	190 + 5	200 + 5	210 + 5	170 + 5	190 + 5
		40 - 20 k	85 + 5	95 + 5	100 + 5	105 + 5	55 + 5	60 + 5
		20 k - 50 k	300 + 5	330 + 5	350 + 5	370 + 5	90 + 5	100 + 5
		50 k - 100 k	700 + 7	750 + 7	800 + 7	850 + 7	210 + 7	230 + 7
		100 k - 300 k	900 + 12	1000 + 12	1050 + 12	1100 + 12	380 + 12	420 + 12
		300 k - 500 k	1300 + 25	1500 + 25	1600 + 25	1700 + 25	900 + 25	1000 + 25
500 k - 1 M	2800 + 25	3100 + 25	3300 + 25	3400 + 25	2900 + 25	3200 + 25		
220 mV	100 nV	10 - 20	400 + 13	500 + 13	530 + 13	550 + 13	400 + 13	500 + 13
		20 - 40	170 + 8	190 + 8	200 + 8	210 + 8	170 + 8	190 + 8
		40 - 20 k	85 + 8	95 + 8	100 + 8	105 + 8	55 + 8	60 + 8
		20 k - 50 k	250 + 8	280 + 8	300 + 8	320 + 8	90 + 8	100 + 8
		50 k - 100 k	700 + 25	750 + 25	800 + 25	850 + 25	210 + 25	230 + 25
		100 k - 300 k	900 + 25	1000 + 25	1050 + 25	1100 + 25	380 + 25	420 + 25
		300 k - 500 k	1300 + 35	1500 + 35	1600 + 35	1700 + 35	900 + 35	1000 + 35
500 k - 1 M	2800 + 80	3100 + 80	3300 + 80	3400 + 80	2900 + 80	3200 + 80		
2.2 V	1 mV	10 - 20	400 + 80	450 + 80	480 + 80	500 + 80	400 + 80	450 + 80
		20 - 40	130 + 25	140 + 25	150 + 25	160 + 25	130 + 25	140 + 25
		40 - 20 k	60 + 6	65 + 6	70 + 6	75 + 6	35 + 6	40 + 6
		20 k - 50 k	105 + 16	110 + 16	115 + 16	120 + 16	85 + 16	95 + 16
		50 k - 100 k	190 + 70	210 + 70	230 + 70	250 + 70	170 + 70	190 + 70
		100 k - 300 k	350 + 130	390 + 130	420 + 130	430 + 130	340 + 130	380 + 130
		300 k - 500 k	850 + 350	950 + 350	1000 + 350	1050 + 350	850 + 350	950 + 350
500 k - 1 M	1700 + 850	1900 + 850	2100 + 850	2200 + 850	1700 + 850	1900 + 850		
22 V	10 mV	10 - 20	400 + 800	450 + 800	480 + 800	500 + 800	400 + 800	450 + 800
		20 - 40	130 + 250	140 + 250	150 + 250	160 + 250	130 + 250	140 + 250
		40 - 20 k	60 + 60	65 + 60	70 + 60	75 + 60	35 + 60	40 + 60
		20 k - 50 k	105 + 160	110 + 160	115 + 160	120 + 160	85 + 160	95 + 160
		50 k - 100 k	190 + 350	210 + 350	230 + 350	250 + 350	170 + 350	190 + 350
		100 k - 300 k	400 + 1500	450 + 1500	470 + 1500	500 + 1500	400 + 1500	450 + 1500
		300 k - 500 k	1050 + 4300	1150 + 4300	1200 + 4300	1250 + 4300	1000 + 4300	1100 + 4300
500 k - 1 M	2300 + 8500	2500 + 8500	2600 + 8500	2700 + 8500	2200 + 8500	2400 + 8500		
± (ppm output + mV)			± (ppm output + mV)				± (ppm output + mV)	
220 V [Note 2]	100 mV	10 - 20	400 + 8	450 + 8	480 + 8	500 + 8	400 + 8	450 + 8
		20 - 40	130 + 2.5	140 + 2.5	150 + 2.5	160 + 2.5	130 + 2.5	140 + 2.5
		40 - 20 k	65 + 0.8	70 + 0.8	75 + 0.8	80 + 0.8	40 + 0.8	45 + 0.8
		20 k - 50 k	170 + 3.5	190 + 3.5	210 + 3.5	220 + 3.5	85 + 3.5	95 + 3.5
		50 k - 100 k	400 + 8	450 + 8	480 + 8	500 + 8	270 + 8	300 + 8
		100 k - 300 k	1300 + 90	1400 + 90	1450 + 90	1500 + 90	1200 + 90	1300 + 90
		300 k - 500 k	4300 + 90	4500 + 90	4600 + 90	4700 + 90	4200 + 90	4500 + 90
500 k - 1 M	10,500 + 190	11,000 + 190	11,300 + 190	11,500 + 190	10,500 + 190	11,000 + 190		
1100 V	1 mV [Note 1]	15 - 50	340 + 16	360 + 16	380 + 16	400 + 16	340 + 16	360 + 16
		50 - 1 k	65 + 3.5	70 + 3.5	75 + 3.5	80 + 3.5	45 + 3.5	50 + 3.5
5725A Amplifier:								
1100 V	1 mV	40 - 1 k	75 + 4	80 + 4	85 + 4	90 + 4	50 + 4	55 + 4
		1 k - 20 k	105 + 6	125 + 6	135 + 6	165 + 6	85 + 6	105 + 6
		20 k - 30 k	230 + 11	360 + 11	440 + 11	600 + 11	160 + 11	320 + 11
750 V		30 k - 50 k	230 + 11	360 + 11	440 + 11	600 + 11	160 + 11	320 + 11
		50 k - 100 k	600 + 45	1300 + 45	1600 + 45	2300 + 45	380 + 45	1200 + 45

Notes: 1. Maximum output 250V from 15-50 Hz.
2. See Volt-Hertz capability in Figure 1-2.

Table 1-8. AC Voltage Secondary Performance Specifications and Operating Characteristics

Range	Frequency	Stability ± 1 °C [Note 1] 24 Hours	Temperature Coefficient		Output Impedance	Maximum Distortion Bandwidth 10 Hz-10 MHz
			10°-40 °C	0°-10 °C and 40°-50 °C		
		Hz	± μV	±μV/°C		Ω
2.2 mV	10 - 20	5	0.05	0.05	50	0.05 + 10
	20 - 40	5	0.05	0.05		0.035 + 10
	40 - 20 k	2	0.05	0.05		0.035 + 10
	20 k - 50 k	2	0.1	0.1		0.035 + 10
	50 k - 100 k	3	0.2	0.2		0.035 + 10
	100 k - 300 k	3	0.3	0.3		0.3 + 30
	300 k - 500 k	5	0.4	0.4		0.3 + 30
500 k - 1 M	5	0.5	0.5	1 + 30		
22 mV	10 - 20	5	0.2	0.3	50	0.05 + 11
	20 - 40	5	0.2	0.3		0.035 + 11
	40 - 20 k	2	0.2	0.3		0.035 + 11
	20 k - 50 k	2	0.4	0.5		0.035 + 11
	50 k - 100 k	3	0.5	0.5		0.035 + 11
	100 k - 300 k	5	0.6	0.6		0.3 + 30
	300 k - 500 k	10	1	1		0.3 + 30
500 k - 1 M	15	1	1	1 + 30		
		± (ppm output + μV)	± (ppm output μV)/°C			
220 mV	10 - 20	150 + 20	2 + 1	2 + 1	50	0.05 + 16
	20 - 40	80 + 15	2 + 1	2 + 1		0.035 + 16
	40 - 20 k	12 + 2	2 + 1	2 + 1		0.035 + 16
	20 k - 50 k	10 + 2	15 + 2	15 + 2		0.035 + 16
	50 k - 100 k	10 + 2	15 + 4	15 + 4		0.035 + 16
	100 k - 300 k	20 + 4	80 + 5	80 + 5		0.3 + 30
	300 k - 500 k	100 + 10	80 + 5	80 + 5		0.3 + 30
500 k - 1 M	200 + 20	80 + 5	80 + 5	1 + 30		
				Load Regulation ±(ppm output+ μV)		
2.2 V	10 - 20	150 + 20	50 + 10	50 + 10	10 + 2	0.05 + 80
	20 - 40	80 + 15	15 + 5	15 + 5	10 + 2	0.035 + 80
	40 - 20 k	12 + 4	2 + 1	5 + 2	10 + 4	0.035 + 80
	20 k - 50 k	15 + 5	10 + 2	15 + 4	30 + 10	0.035 + 80
	50 k - 100 k	15 + 5	10 + 4	20 + 4	120 + 16	0.035 + 80
	100 k - 300 k	30 + 10	80 + 15	80 + 15	300 ppm	0.3 + 110
	300 k - 500 k	70 + 20	80 + 40	80 + 40	600 ppm	0.3 + 110
500 k - 1 M	150 + 50	80 + 100	80 + 100	1200 ppm	1 + 110	
22 V	10 - 20	150 + 20	50 + 100	50 + 100	10 + 20	0.05 + 700
	20 - 40	80 + 15	15 + 30	15 + 40	10 + 20	0.035 + 700
	40 - 20 k	12 + 8	2 + 10	4 + 15	10 + 30	0.035 + 700
	20 k - 50 k	15 + 10	10 + 20	20 + 20	30 + 50	0.035 + 700
	50 k - 100 k	15 + 10	10 + 40	20 + 40	80 + 80	0.035 + 700
	100 k - 300 k	30 + 15	80 + 150	80 + 150	100 + 700	0.3 + 800
	300 k - 500 k	70 + 100	80 + 300	80 + 300	200 + 1100	0.3 + 800
500 k - 1 M	150 + 100	80 + 500	80 + 500	600 + 3000	2 + 800	
220 V	10 - 20	150 + 200	50 + 1000	50 + 1000	10 + 200	0.05 + 10,000
	20 - 40	80 + 150	15 + 300	15 + 300	10 + 200	0.05 + 10,000
	40 - 20 k	12 + 80	2 + 80	4 + 80	10 + 300	0.05 + 10,000
	20 k - 50 k	15 + 100	10 + 100	20 + 100	30 + 600	0.05 + 10,000
	50 k - 100 k	15 + 100	10 + 500	20 + 500	80 + 3,000	0.1 + 13,000
	100 k - 300 k	30 + 400	80 + 600	80 + 600	250 + 25,000	1.5 + 50,000
	300 k - 500 k	100 + 10,000	80 + 800	80 + 800	500 + 50,000	1.5 + 50,000
500 k - 1 M	200 + 20,000	80 + 1000	80 + 1000	1000 + 110,000	3.5 + 100,000	
		±(ppm output + mV)	±(ppm output)/°C			±(% output)
1100 V	15 - 50	150 + 0.5	50	50	10 + 2	0.15
	50 - 1 k	20 + 0.5	2	5	10 + 1	0.07

Note: 1. Stability specifications are included in Absolute Uncertainty values for the primary specifications.

Table 1-8. AC Voltage Secondary Performance and Operating Characteristics (continued)

5725A Amplifier:

Range	Frequency	Stability ±1 °C [Note 1] 24 Hours	Temperature Coefficient Adder		Load Regulation [Note 2]	Distortion Bandwidth 10 Hz-10 MHz ±(% output)	
			10°-40 °C	0°-10 °C and 40°-50 °C		150 pF	1000 pF
	Hz	±(ppm output + mV)	±(ppm output)/°C		±(ppm output + mV)	150 pF	1000 pF
1100 V	40 - 1 k	10 + .5	5	5	10 + 1	0.10	0.10
	1 k - 20 k	15 + 2	5	5	90 + 6	0.10	0.15
	20 k - 50 k	40 + 2	10	10	275 + 11	0.30	0.30
	50 k - 100 k	130 + 2	30	30	500 + 30	0.40	0.40

Voltage Range	Maximum Current Limits	Load Limits
2.2 V [Note 3] 22 V 220 V	50 mA, 0 °C-40 °C 20 mA, 40 °C-50 °C	>50 Ω, 1000 pF
1100 V	6 mA	600 pF
5725A Amplifier:		1000 pF [Note 2]
1100 V	40 Hz-5 kHz	50 mA
	5 kHz-30 kHz	70 mA
	30 kHz-100 kHz	70 mA [Note 4]

Output display formats: Voltage or dBm,
dBm reference 600 Ω.

Minimum output:: 10 % on each range

External sense: Selectable for 2.2 V, 22 V, 220 V, and
1100 V ranges; 5700A/5720A <100 kHz, 5725A <30 kHz

Settling time to full accuracy:

Frequency (Hz)	Settling time (seconds)
<20	7
120-120 k	5
>120 k	2

Notes:

- Stability specifications are included in Absolute Uncertainty values for the primary specifications.
- The 5725A will drive up to 1000 pF of load capacitance. Uncertainty specifications include loads to 300 pF and 150 pF as shown under "Load Limits." For capacitances up to the maximum of 1000 pF, add "Load Regulation."
- 2.2 V Range, 100 kHz-1.2 MHz only: uncertainty specifications cover loads to 10 mA or 1000 pF. For higher loads, load regulation is added.
- Applies from 0 °C to 40 °C

- + 1 second for amplitude or frequency range change;
- + 2 seconds for 5700A/5720A 1100 V range;
- + 4 seconds for 5725A 1100 V range

Overshoot:: <10%

Common mode rejection: 140 dB, DC to 400 Hz

Frequency:

Ranges (Hz):

- 10.000-119.99
- 0.1200 k-1.1999 k, 1.200 k-11.999 k
- 12.00 k-119.99 k, 120.0 k-1.1999

Uncertainty: ±0.01 %

Resolution: 11.999 counts

Phase lock: Selectable rear panel BNC input

Phase uncertainty (except 1100 V range):

>30 Hz: ±1° + 0.05°/kHz, <30 Hz: ±3°

Input voltage: 1 V to 10 V rms sine wave (do not exceed 1 V for mV ranges)

Frequency range: 10 Hz to 1.1999 MHz

Lock range: ±2 % of frequency

Lock-in time: Larger of 10/frequency or 10 msec

Phase reference: Selectable, rear panel BNC output

Range: ±180°

Phase Uncertainty (except 1100 V range):

+1° at quadrature points (0°, +90°, +180°) elsewhere
±2°

Stability: ±0.1°

Resolution: 1°

Output level: 2.5 V rms ±0.2 V

Frequency range:

50 kHz to 1 kHz, usable 10 Hz to 1.1999 MHz

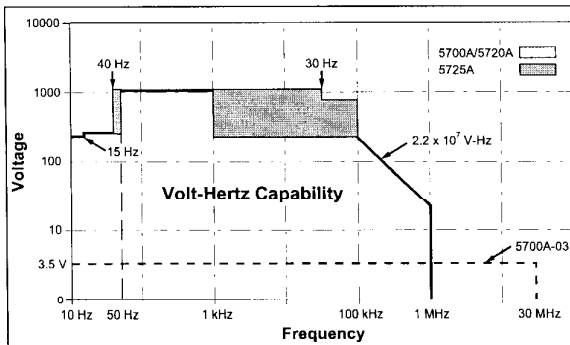

Figure 1-1. Volt-Hertz Capability

1-14. Resistance Specifications

Table 1-9. 5720A Series II Resistance Specifications: 99 % and 95 % Confidence Levels

5720A
99%

99% Confidence Level

Nominal Value	Absolute Uncertainty of Characterized Value ±5 °C from calibration temperature [Note 1]			
	24 Hours	90 Days	180 Days	1 Year
Ω	±ppm			
0	50 μΩ	50 μΩ	50 μΩ	50 μΩ
1	85	95	100	110
1.9	85	95	100	110
10	23	25	26	27
19	23	25	26	27
100	10	11	11.5	12
190	10	11	11.5	12
1 k	8	9	9.5	10
1.9 k	8	9	9.5	10
10 k	8	9	9.5	10
19 k	9	9	9.5	10
100 k	9	11	12	13
190 k	9	11	12	13
1 M	16	18	20	23
1.9 M	17	19	21	24
10 M	33	37	40	46
19 M	43	47	50	55
100 M	100	110	115	120

Relative Uncertainty ±1 °C	
24 Hours	90 Days
±ppm	
50 μΩ	50 μΩ
32	40
25	33
5	8
4	7
2	4
2	4
2	3
2	3
2	3
2	3
2	3
2	3
2.5	5
3	6
10	14
20	24
50	60

5720A
95%

95% Confidence Level

Nominal Value	Absolute Uncertainty of Characterized Value ±5 °C from calibration temperature [Note 1]			
	24 Hours	90 Days	180 Days	1 Year
Ω	±ppm			
0	40 μΩ	40 μΩ	40 μΩ	40 μΩ
1	70	80	85	95
1.9	70	80	85	95
10	20	21	22	23
19	20	21	22	23
100	8	9	9.5	10
190	8	9	9.5	10
1 k	6.5	7.5	8	8.5
1.9 k	6.5	7.5	8	8.5
10 k	6.5	7.5	8	8.5
19 k	7.5	7.5	8	8.5
100 k	7.5	9	10	11
190 k	7.5	9	10	11
1 M	13	15	17	20
1.9 M	14	16	18	21
10 M	27	31	34	40
19 M	35	39	42	57
100 M	85	95	100	100

Relative Uncertainty ±1 °C	
24 Hours	90 Days
±ppm	
40 μΩ	40 μΩ
27	35
20	26
4	7
3.5	6
1.6	3.5
1.6	3.5
1.6	2.5
1.6	2.5
1.6	2.5
1.6	2.5
1.6	2.5
1.6	2.5
2	4
2.5	4
8	12
16	20
40	50

Note: 1. Specifications apply to displayed value. 4-wire connections, except 100 MΩ.

Table 1-10. 5700A Series II Resistance Specifications: 99 % and 95 % Confidence Levels

5700A
99%

99 % Confidence Level

Nominal Value	Absolute Uncertainty of Characterized Value ±5 °C from calibration temperature [Note 1]			
	24 Hours	90 Days	180 Days	1 Year
Ω	±ppm			
0	50 μΩ	50 μΩ	50 μΩ	50 μΩ
1	85	95	100	110
1.9	85	95	100	110
10	26	28	30	33
19	24	26	28	31
100	15	17	18	20
190	15	17	18	20
1 k	11	12	13	15
1.9 k	11	12	13	15
10 k	9	11	12	14
19 k	9	11	12	14
100 k	11	13	14	16
190 k	11	13	14	16
1 M	16	18	20	23
1.9 M	17	19	21	24
10 M	33	37	40	46
19 M	43	47	50	55
100 M	110	120	125	130

Relative Uncertainty ±1 °C	
24 Hours	90 Days
±ppm	
50 μΩ	50 μΩ
32	40
25	33
5	8
4	7
2	4
2	4
2	3.5
2	3.5
2	3.5
2	3.5
2	3.5
2.5	5
3.5	6
10	14
20	24
50	60

5700A
95%

95 % Confidence Level

Nominal Value	Absolute Uncertainty of Characterized Value ±5 °C from calibration temperature [Note 1]			
	24 Hours	90 Days	180 Days	1 Year
Ω	±ppm			
0	50 μΩ	50 μΩ	50 μΩ	50 μΩ
1	70	80	85	95
1.9	70	80	85	95
10	21	23	27	28
19	20	22	24	27
100	13	14	15	17
190	13	14	15	17
1 k	9	10	11	13
1.9 k	9	10	11	13
10 k	7.5	9.5	10.5	12
19 k	7.5	9.5	10.5	12
100 k	9	11	12	14
190 k	9	11	12	14
1 M	13	15	17	20
1.9 M	14	16	18	21
10 M	27	31	34	40
19 M	35	39	42	47
100 M	90	100	105	110

Relative Uncertainty ±1 °C	
24 Hours	90 Days
±ppm	
50 μΩ	50 μΩ
32	40
25	33
5	8
4	7
2	4
2	4
2	3.5
2	3.5
2	3.5
2	3.5
2	3.5
2.5	5
3	6
10	14
20	24
50	60

Note: 1. Specifications apply to displayed value. 4-wire connections, except 100 MΩ.

Table 1-11. Resistance Secondary Performance Specifications and Operating Characteristics

Nominal Value	Stability ±1 °C [Note 1] 24 Hours	Temperature Coefficient Adder [Note 2]		Full Spec Load Range [Note 3]	Maximum Peak Current	Maximum Difference of Characterized to Nominal Value	Two-Wire Adder active compensation [Note 4]	
		10°-40 °C	0°-10 °C and 40°-50 °C				Lead Resistance	
							0.1Ω	1Ω
Ω	±ppm	±ppm/°C		mA	mA	±ppm	±mΩ	
0	—	—	—	8 - 500	500	—	$2 + \frac{4\mu V}{I_m}$	$4 + \frac{4\mu V}{I_m}$
1	32	4	5	8 - 100	700	500	$2 + \frac{4\mu V}{I_m}$	$4 + \frac{4\mu V}{I_m}$
1.9	25	6	7	8 - 100	500	500	$2 + \frac{4\mu V}{I_m}$	$4 + \frac{4\mu V}{I_m}$
10	5	2	3	8 - 11	220	300	$2 + \frac{4\mu V}{I_m}$	$4 + \frac{4\mu V}{I_m}$
19	4	2	3	8 - 11	160	300	$2 + \frac{4\mu V}{I_m}$	$4 + \frac{4\mu V}{I_m}$
100	2	2	3	8 - 11	70	150	$2 + \frac{4\mu V}{I_m}$	$4 + \frac{4\mu V}{I_m}$
190	2	2	3	8 - 11	50	150	$2 + \frac{4\mu V}{I_m}$	$4 + \frac{4\mu V}{I_m}$
1 k	2	2	3	1 - 2	22	150	10	15
1.9 k	2	2	3	1 - 1.5	16	150	10	15
10 k	2	2	3	100 - 500 μA	7	150	50	60
19 k	2	2	3	50 - 250 μA	5	150	100	120
100 k	2	2	3	10 - 100 μA	1	150	I _m = Current produced by Ohmmeter	
190 k	2	2	3	5 - 50 μA	500 μA	150		
1 M	2.5	2.5	6	5 - 20 μA	100 μA	200		
1.9 M	3.5	3	10	2.5 - 10 μA	50 μA	200		
10 M	10	5	20	0.5 - 2 μA	10 μA	300		
19 M	20	8	40	0.25 - 1 μA	5 μA	300		
100 M	50	12	100	50 - 200 nA	1 μA	500		

Notes:

- Stability specifications are included in the Absolute Uncertainty values in the primary specification tables.
- Temperature coefficient is an adder to uncertainty specifications that does not apply unless operated more than 5 °C from calibration temperature, or calibrated outside the range 19 °C to 24 °C. Two examples:
 - Calibrate at 20 °C: Temperature coefficient adder is not required unless operated below 15 °C or above 25 °C.
 - Calibrate at 26 °C: Add 2 °C temperature coefficient adder. Additional temperature coefficient adder is not required unless operated below 21 °C or above 31 °C.
- Refer to current derating factors table for loads outside of this range.
- Active two-wire compensation may be selected for values less than 100 kΩ, with either the front panel or the meter input terminals as reference plane. Active compensation is limited to 11 mA load, and to 2 V burden. Two-wire compensation can be used only with Ω-meters that source continuous (not pulsed) dc current.

Table 1-12. Current Derating Factors

Nominal Value	Value of Derating Factor K for Over or Under Current		
	Two-Wire Comp $I < I_L$ [Note 1]	Four-Wire $I < I_L$ [Note 1]	Four-Wire $I_U < I < I_{max}$ [Note 2]
SHORT	4.4	0.3	—
1	4.4	300	4×10^{-5}
1.9	4.4	160	1.5×10^{-4}
10	4.4	30	1.6×10^{-3}
19	4.4	16	3×10^{-3}
100	4.4	3.5	1×10^{-2}
190	4.4	2.5	1.9×10^{-2}
1 k	4.4	0.4	0.1
1.9 k	4.4	0.4	0.19
10 k	5000	50	2.0
19 k	5000	50	3.8
100 k	—	7.5	2×10^{-5}
190 k	—	4.0	3.8×10^{-5}
1 M	—	1.0	1.5×10^{-4}
1.9 M	—	0.53	2.9×10^{-4}
10 M	—	0.2	1×10^{-3}
19 M	—	0.53	1.9×10^{-3}
100 M	—	0.1	—

Notes:

- For $I < I_L$, errors occur due to thermally generated voltages within the 5720A. Use the following equation to determine the error, and add this error to the corresponding uncertainty or stability specification.

$$\text{Error} = K(I_L - I) / (I_L \times I)$$

Where: Error is in mΩ for all two-wire comp values and four-wire short, and in ppm for the remaining four-wire values.

K is the constant from the above table;

I and I_L are expressed in mA for short to 1.9 kΩ;

I and I_L are expressed in μA for 10 kΩ to 100 MΩ

- For $I_U < I < I_{MAX}$ errors occur due to self-heating of the resistors in the calibrator. Use the following equation to determine the error in ppm and add this error to the corresponding uncertainty or stability specification.

$$\text{Error in ppm} = K(I^2 - I_U^2)$$

Where: K is the constant from the above table;

I and I_U are expressed in mA for short to 19 kΩ;

I and I_U are expressed in μA for 100 kΩ to 100 MΩ

1-15. DC Current Specifications

Table 1-13. 5720A Series II DC Current Specifications: 99 % and 95 % Confidence Levels

5720A 99%		99 % Confidence Level					Relative Uncertainty $\pm 1^\circ\text{C}$	
Range	Resolution	Absolute Uncertainty $\pm 5^\circ\text{C}$ from calibration temperature. For fields strengths $>0.4\text{ V/m}$ but $\leq 3\text{ V/m}$, add 1 % of range.				24 Hours	90 Days	
		24 Hours	90 Days	180 Days	1 Year	24 Hours	90 Days	
		$\pm (\text{ppm output} + \text{nA})$						
220 μA	0.1	40 + 7	42 + 7	45 + 7	50 + 7	24 + 7	26 + 7	
2.2 mA	1	30 + 8	35 + 8	37 + 8	40 + 8	24 + 8	26 + 8	
22 mA	10	30 + 50	35 + 50	37 + 50	40 + 50	24 + 50	26 + 50	
		$\pm (\text{ppm output} + \mu\text{A})$						
220 mA	0.1	40 + 0.8	45 + 0.8	47 + 0.8	50 + 0.8	26 + 0.5	30 + 0.5	
2.2 A	1	60 + 15	70 + 15	80 + 15	90 + 15	40 + 12	45 + 12	
[Note 1]								
5725A Amplifier:								
11 A	10	330 + 470	340 + 480	350 + 480	360 + 480	100 + 130	110 + 130	

5720A 95%		95 % Confidence Level					Relative Uncertainty $\pm 1^\circ\text{C}$	
Range	Resolution	Absolute Uncertainty $\pm 5^\circ\text{C}$ from calibration temperature For fields strengths $>0.4\text{ V/m}$ but $\leq 3\text{ V/m}$, add 1 % of range.				24 Hours	90 Days	
		24 Hours	90 Days	180 Days	1 Year	24 Hours	90 Days	
		$\pm (\text{ppm output} + \text{nA})$						
220 μA	0.1	32 + 6	35 + 6	37 + 6	40 + 6	20 + 6	22 + 6	
2.2 mA	1	25 + 7	30 + 7	33 + 7	35 + 7	20 + 7	22 + 7	
22 mA	10	25 + 40	30 + 40	33 + 40	35 + 40	20 + 40	22 + 40	
		$\pm (\text{ppm output} + \mu\text{A})$						
220 mA	0.1	35 + 0.7	40 + 0.7	42 + 0.7	45 + 0.7	20 + 0.7	25 + 0.7	
2.2 A	1	50 + 12	60 + 12	70 + 12	80 + 12	32 + 12	40 + 12	
[Note 1]								
5725A Amplifier:								
11 A	10	330 + 470	340 + 480	350 + 480	360 + 480	100 + 130	110 + 130	

Note: Maximum output from calibrator terminals is 2.2 A. Uncertainty specifications for 220 mA and 2.2 mA ranges are increased by a factor of 1.3 when supplied through 5725A terminals.

Specifications are otherwise identical for all output locations.

1. Add to uncertainty specifications:

$$\pm 200 \times I^2 \text{ ppm for } >100 \text{ mA on } 220 \text{ mA range}$$

$$\pm 10 \times I^2 \text{ ppm for } >1 \text{ A on } 2.2 \text{ A range}$$

Table 1-14. 5700A Series II DC Current Specifications: 99 % and 95 % Confidence Levels

5700A
99%

99 % Confidence Level

Range	Resolution	Absolute Uncertainty ±5 °C from calibration temperature For fields strengths >0.4 V/m but ≤3 V/m, add 1% of range.				Relative Uncertainty ±1 °C	
		24 Hours	90 Days	180 Days	1 Year	24 Hours	90 Days
	nA	± (ppm output + nA)				± (ppm output + nA)	
220 µA	0.1	45 + 10	50 + 10	55 + 10	60 + 10	24 + 2	26 + 2
2.2 mA	1	45 + 10	50 + 10	55 + 10	60 + 10	24 + 5	26 + 5
22 mA	10	45 + 100	50 + 100	55 + 100	60 + 100	24 + 50	26 + 50
	µA	± (ppm output + µA)				± (ppm output + µA)	
220 mA	0.1	55 + 1	60 + 1	65 + 1	70 + 1	26 + .3	30 + .3
2.2 A	1	75 + 30	80 + 30	90 + 30	95 + 30	40 + 7	45 + 7
[Note 1]							
5725A Amplifier:							
11 A	10	330 + 470	340 + 480	350 + 480	360 + 480	100 + 130	110 + 130

5700A
95%

95 % Confidence Level

Range	Resolution	Absolute Uncertainty ±5 °C from calibration temperature For fields strengths >0.4 V/m but ≤3 V/m, add 1% of range.				Relative Uncertainty ±1 °C	
		24 Hours	90 Days	180 Days	1 Year	24 Hours	90 Days
	nA	± (ppm output + nA)				± (ppm output + nA)	
220 µA	0.1	35 + 8	40 + 8	45 + 8	50 + 8	20 + 1.6	22 + 1.6
2.2 mA	1	35 + 8	40 + 8	45 + 8	50 + 8	20 + 4	22 + 4
22 mA	10	35 + 80	40 + 80	45 + 80	50 + 80	20 + 80	22 + 80
	µA	± (ppm output + µA)				± (ppm output + µA)	
220 mA	0.1	45 + 0.8	50 + 0.8	55 + 0.8	60 + 0.8	22 + 0.25	25 + 0.25
2.2 A	1	60 + 25	65 + 25	75 + 25	80 + 25	35 + 6	40 + 6
[Note 1]							
5725A Amplifier:							
11 A	10	330 + 470	340 + 480	350 + 480	360 + 480	100 + 130	110 + 130

Note: Maximum output from the calibrator's terminals is 2.2 A. Uncertainty specifications for 220 mA and 2.2 mA ranges are increased by a factor of 1.3 when supplied through 5725A terminals.

Specifications are otherwise identical for all output locations.

1. Add to uncertainty specifications:

- ±200 x I² ppm for >100 mA on 220 mA range
- ±10 x I² ppm for >1A on 2.2A range

Table 1-15. DC Current Secondary Performance Specifications and Operating Characteristics

Range	Stability ±1 °C [Note 1] 24 Hours	Temperature Coefficient [Note 2]		Compliance Limits	Burden Voltage Adder [Note 3]	Maximum Load for Full Accuracy [Note 4]	Noise	
		10 °-40 °C	0 °-10 °C and 40 °-50 °C				Bandwidth 0.1-10 Hz	Bandwidth 10 Hz-10 kHz
		± (ppm output + nA)/ °C					pk-pk	RMS
	± (ppm output + nA)	± (ppm output + nA)/ °C			±nA/V	Ω	ppm output + nA	nA
220 µA	5 + 1	1 + 0.40	3 + 1	10	0.2	20k	6 + .9	10
2.2 mA	5 + 5	1 + 2	3 + 10	10	0.2	2k	6 + 5	10
22 mA	5 + 50	1 + 20	3 + 100	10	10	200	6 + 50	50
220 mA	8 + 300	1 + 200	3 + 1 µA	10	100	20	9 + 300	500
2.2 A	9 + 7 µA	1 + 2.5 µA	3 + 10 µA	3 [Note 5]	2 µA	2	12 + 1.5 µA	20 µA
5725A	± (ppm output + µA)	± (ppm output + µA)/ °C					ppm output + µA	µA
11 A	25 + 100	20 + 75	30 + 120	4		4	15 + 70	175

Notes:

Maximum output from the calibrator's terminals is 2.2 A. Uncertainty specifications for 220 mA and 2.2 mA ranges are increased by a factor of 1.3 when supplied through 5725A terminals.

1. Stability specifications are included in the Absolute Uncertainty values for the primary specifications.
2. Temperature coefficient is an adder to uncertainty specifications. It does not apply unless operating more than ±5 °C from calibration temperature.
3. Burden voltage adder is an adder to uncertainty specifications that does not apply unless burden voltage is greater than 0.5 V.
4. For higher loads, multiply uncertainty specification by: $1 + \frac{0.1 \times \text{actual load}}{\text{maximum load for full accuracy}}$
5. The calibrator's compliance limit is 2 V for outputs from 1 A to 2.2 A. 5725A Amplifier may be used in range-lock mode down to 0 A.

Minimum output: 0 for all ranges, including 5725A.

Settling time to full accuracy: 1 second for mA and mA ranges; 3 seconds for 2.2 A range; 6 seconds for 11 A range; + 1 second for range or polarity change

Overshoot: <5 %

1-16. AC Current Specifications

Table 1-16. 5720A Series II AC Current Specifications: 99 % Confidence Level

5720A
99%

99 % Confidence Level

Range	Resolution	Frequency	Absolute Uncertainty ±5 °C from calibration temperature For fields strengths >0.4 V/m but ≤3 V/m, add 1 % of range.				Relative Uncertainty ±1 °C	
			24 Hours	90 Days	180 Days	1 Year	24 Hours	90 Days
			Hz	± (ppm output + nA)				± (ppm output + nA)
220 µA	1 nA	10 - 20	260 + 20	280 + 20	290 + 20	300 + 20	260 + 20	280 + 20
		20 - 40	170 + 12	180 + 12	190 + 12	200 + 12	130 + 12	150 + 12
		40 - 1 k	120 + 10	130 + 10	135 + 10	140 + 10	100 + 10	110 + 10
		1k - 5 k	300 + 15	320 + 15	340 + 15	350 + 15	250 + 15	280 + 15
		5k - 10 k	1000 + 80	1100 + 80	1200 + 80	1300 + 80	900 + 80	1000 + 80
2.2 mA	10 nA	10 - 20	260 + 50	280 + 50	290 + 50	300 + 50	260 + 50	280 + 50
		20 - 40	170 + 40	180 + 40	190 + 40	200 + 40	130 + 40	150 + 40
		40 - 1 k	120 + 40	130 + 40	135 + 40	140 + 40	100 + 40	110 + 40
		1k - 5 k	210 + 130	220 + 130	230 + 130	240 + 130	250 + 130	280 + 130
		5k - 10 k	1000 + 800	1100 + 800	1200 + 800	1300 + 800	900 + 800	1000 + 800
22 mA	100 nA	10 - 20	260 + 500	280 + 500	290 + 500	300 + 500	260 + 500	280 + 500
		20 - 40	170 + 400	180 + 400	190 + 400	200 + 400	130 + 400	150 + 400
		40 - 1 k	120 + 400	130 + 400	135 + 400	140 + 400	100 + 400	110 + 400
		1k - 5 k	210 + 700	220 + 700	230 + 700	240 + 700	250 + 700	280 + 700
		5k - 10 k	1000 + 6000	1100 + 6000	1200 + 6000	1300 + 6000	900 + 6000	1000 + 6000
		Hz	± (ppm output + µA)				± (ppm output + µA)	
220 mA	1 µA	10 - 20	260 + 5	280 + 5	290 + 5	300 + 5	260 + 5	280 + 5
		20 - 40	170 + 4	180 + 4	190 + 4	200 + 4	130 + 4	150 + 4
		40 - 1 k	120 + 3	130 + 3	135 + 3	140 + 3	100 + 3	110 + 3
		1k - 5 k	210 + 4	220 + 4	230 + 4	240 + 4	250 + 4	280 + 4
		5k - 10 k	1000 + 12	1100 + 12	1200 + 12	1300 + 12	900 + 12	1000 + 12
2.2 A	10 µA	20 - 1 k	290 + 40	300 + 40	310 + 40	320 + 40	300 + 40	350 + 40
		1 k - 5 k	440 + 100	460 + 100	480 + 100	500 + 100	500 + 100	520 + 100
		5 k - 10 k	6000 + 200	7000 + 200	7500 + 200	8000 + 200	6000 + 200	7000 + 200
5725A Amplifier:								
11 A	100 µA	40 - 1 k	370 + 170	400 + 170	440 + 170	460 + 170	300 + 170	330 + 170
		1 k - 5 k	800 + 380	850 + 380	900 + 380	950 + 380	700 + 380	800 + 380
		5 k - 10 k	3000 + 750	3300 + 750	3500 + 750	3600 + 750	2800 + 750	3200 + 750

Note: Maximum output from the calibrator's terminals is 2.2 A. Uncertainty specifications for 220 µA and 2.2 mA ranges are increased by a factor of 1.3 plus 2 µA when supplied through 5725A terminals. Specifications are otherwise identical for all output locations.

Table 1-17. 5720A Series II AC Current Specifications: 95 % Confidence Level

Range		Resolution		Frequency		Absolute Uncertainty ±5 °C from calibration temperature For fields strengths >0.4 V/m but ≤3 V/m, add 1 % of range.				Relative Uncertainty ±1 °C	
						24 Hours	90 Days	180 Days	1 Year	24 Hours	90 Days
						Hz				± (ppm output + nA)	
220 μA	1 nA	10 - 20	210 + 16	230 + 16	240 + 16	250 + 16	210 + 16	230 + 16			
		20 - 40	130 + 10	140 + 10	150 + 10	160 + 10	110 + 10	130 + 10			
		40 - 1 k	100 + 8	110 + 8	115 + 8	120 + 8	80 + 8	90 + 8			
		1k - 5 k	240 + 12	250 + 12	270 + 12	280 + 12	200 + 12	230 + 12			
		5k - 10 k	800 + 65	900 + 65	1000 + 65	1100 + 65	700 + 65	800 + 65			
2.2 mA	10 nA	10 - 20	210 + 40	230 + 40	240 + 40	250 + 40	210 + 40	230 + 40			
		20 - 40	140 + 35	140 + 35	150 + 35	160 + 35	110 + 35	130 + 35			
		40 - 1 k	100 + 35	110 + 35	115 + 35	120 + 35	80 + 35	90 + 35			
		1k - 5 k	170 + 110	180 + 110	190 + 110	200 + 110	200 + 110	230 + 110			
		5k - 10 k	800 + 650	900 + 650	1000 + 650	1100 + 650	700 + 650	800 + 650			
22 mA	100 nA	10 - 20	210 + 400	230 + 400	240 + 400	250 + 400	210 + 400	230 + 400			
		20 - 40	130 + 350	140 + 350	150 + 350	160 + 350	110 + 350	130 + 350			
		40 - 1 k	100 + 350	110 + 350	115 + 350	120 + 350	80 + 350	90 + 350			
		1k - 5 k	170 + 550	180 + 550	190 + 550	200 + 550	200 + 550	230 + 550			
		5k - 10 k	800 + 5000	900 + 5000	1000 + 5000	1100 + 5000	700 + 5000	800 + 5000			
220 mA	1 μA	10 - 20	210 + 4	230 + 4	240 + 4	250 + 4	210 + 4	230 + 4			
		20 - 40	130 + 3.5	140 + 3.5	150 + 3.5	160 + 3.5	110 + 3.5	130 + 3.5			
		40 - 1 k	100 + 2.5	110 + 2.5	115 + 2.5	120 + 2.5	80 + 2.5	90 + 2.5			
		1k - 5 k	170 + 3.5	180 + 3.5	190 + 3.5	200 + 3.5	200 + 3.5	230 + 3.5			
		5k - 10 k	800 + 10	900 + 10	1000 + 10	1100 + 10	700 + 10	800 + 10			
2.2 A	10 μA	20 - 1 k	230 + 35	240 + 35	250 + 35	260 + 35	250 + 35	300 + 35			
		1 k - 5 k	350 + 80	390 + 80	420 + 80	450 + 80	400 + 80	440 + 80			
		5 k - 10 k	5000 + 160	6000 + 160	6500 + 160	7000 + 160	5000 + 160	6000 + 160			
5725A Amplifier:											
11 A	100 μA	40 - 1 k	370 + 170	400 + 170	440 + 170	460 + 170	300 + 170	330 + 170			
		1 k - 5 k	800 + 380	850 + 380	900 + 380	950 + 380	700 + 380	800 + 380			
		5 k - 10 k	3000 + 750	3300 + 750	3500 + 750	3600 + 750	2800 + 750	3200 + 750			

Note: Maximum output from the calibrator's terminals is 2.2 A. Uncertainty specifications for 220 μA and 2.2 mA ranges are increased by 1.3 x plus 2 μA when supplied through 5725A terminals. Specifications are otherwise identical for all output locations.

Table 1-18. 5700A Series II AC Current Specifications: 99 % Confidence Level

5700A
99%

99 % Confidence Level

Range	Resolution	Frequency	Absolute Uncertainty ±5 °C from calibration temperature For fields strengths >0.4 V/m but ≤3 V/m, add 1 % of range.				Relative Uncertainty ±1 °C	
			24 Hours	90 Days	180 Days	1 Year	24 Hours	90 Days
			Hz	± (ppm output + nA)				± (ppm output + nA)
220 µA	1 nA	10 - 20	650 + 30	700 + 30	750 + 30	800 + 30	450 + 30	500 + 30
		20 - 40	350 + 25	380 + 25	410 + 25	420 + 25	270 + 25	300 + 25
		40 - 1 k	120 + 20	140 + 20	150 + 20	160 + 20	110 + 20	120 + 20
		1k - 5 k	500 + 50	600 + 50	650 + 50	700 + 50	450 + 50	500 + 50
		5k - 10 k	1500 + 100	1600 + 100	1700 + 100	1800 + 100	1400 + 100	1500 + 100
2.2 mA	10 nA	10 - 20	650 + 50	700 + 50	750 + 50	800 + 50	450 + 50	500 + 50
		20 - 40	350 + 40	380 + 40	410 + 40	420 + 40	270 + 40	300 + 40
		40 - 1 k	120 + 40	140 + 40	150 + 40	160 + 40	110 + 40	120 + 40
		1k - 5 k	500 + 500	600 + 500	650 + 500	700 + 500	450 + 500	500 + 500
		5k - 10 k	1500 + 1000	1600 + 1000	1700 + 1000	1800 + 1000	1400 + 1000	1500 + 1000
22 mA	100 nA	10 - 20	650 + 500	700 + 500	750 + 500	800 + 500	450 + 500	500 + 500
		20 - 40	350 + 400	380 + 400	410 + 400	420 + 400	270 + 400	300 + 400
		40 - 1 k	120 + 400	140 + 400	150 + 400	160 + 400	110 + 400	120 + 400
		1k - 5 k	500 + 5000	600 + 5000	650 + 5000	700 + 5000	450 + 5000	500 + 5000
		5k - 10 k	1500 + 10,000	1600 + 10,000	1700 + 10,000	1800 + 10,000	1400 + 10,000	1500 + 10,000
		Hz	± (ppm output + µA)				± (ppm output + µA)	
220 mA	1 µA	10 - 20	650 + 5	700 + 5	750 + 5	800 + 5	450 + 5	500 + 5
		20 - 40	350 + 4	380 + 4	410 + 4	420 + 4	280 + 4	300 + 4
		40 - 1 k	120 + 4	150 + 4	170 + 4	180 + 4	110 + 4	130 + 4
		1k - 5 k	500 + 50	600 + 50	650 + 50	700 + 50	450 + 50	500 + 50
		5k - 10 k	1500 + 100	1600 + 100	1700 + 100	1800 + 100	1400 + 100	1500 + 100
2.2 A	10 µA	20 - 1 k	600 + 40	650 + 40	700 + 40	750 + 40	600 + 40	650 + 40
		1 k - 5 k	700 + 100	750 + 100	800 + 100	850 + 100	650 + 100	750 + 100
		5 k - 10 k	8000 + 200	9000 + 200	9500 + 200	10,000 + 200	7500 + 200	8500 + 200
5725A Amplifier:								
11 A	100 µA	40 - 1 k	370 + 170	400 + 170	440 + 170	460 + 170	300 + 170	330 + 170
		1 k - 5 k	800 + 380	850 + 380	900 + 380	950 + 380	700 + 380	800 + 380
		5 k - 10 k	3000 + 750	3300 + 750	3500 + 750	3600 + 750	2800 + 750	3200 + 750

Note: Maximum output from the calibrator's terminals is 2.2 A. Uncertainty specifications for 220 µA and 2.2 mA ranges are increased by 1.3 x plus 2 µA when supplied through 5725A terminals. Specifications are otherwise identical for all output locations.

Table 1-19. 5700A Series II AC Current Specifications: 95 % Confidence Level

Range		Resolution		Frequency		Absolute Uncertainty ±5 °C from calibration temperature For fields strengths >0.4 V/m but ≤3 V/m, add 1 % of range.				Relative Uncertainty ±1 °C	
						24 Hours	90 Days	180 Days	1 Year	24 Hours	90 Days
						Hz				± (ppm output + nA)	
220 μA	1 nA	10 - 20	550 + 25	600 + 25	650 + 25	700 + 25	375 + 25	400 + 25			
		20 - 40	280 + 20	310 + 20	330 + 20	350 + 20	220 + 20	250 + 20			
		40 - 1 k	100 + 16	120 + 16	130 + 16	140 + 16	90 + 16	100 + 16			
		1k - 5 k	400 + 40	500 + 40	550 + 40	600 + 40	375 + 40	400 + 40			
		5k - 10 k	1300 + 80	1400 + 80	1500 + 80	1600 + 80	1200 + 80	1200 + 80			
2.2 mA	10 nA	10 - 20	550 + 40	600 + 40	650 + 40	700 + 40	375 + 40	400 + 40			
		20 - 40	280 + 35	310 + 35	330 + 35	350 + 35	220 + 35	250 + 35			
		40 - 1 k	100 + 35	120 + 35	130 + 35	140 + 35	90 + 35	100 + 35			
		1k - 5 k	400 + 400	500 + 400	550 + 400	600 + 400	375 + 400	400 + 400			
		5k - 10 k	1300 + 800	1400 + 800	1500 + 800	1600 + 800	1200 + 800	1200 + 800			
22 mA	100 nA	10 - 20	550 + 400	600 + 400	650 + 400	700 + 400	375 + 400	400 + 400			
		20 - 40	280 + 350	310 + 350	330 + 350	350 + 350	220 + 350	250 + 350			
		40 - 1 k	100 + 350	120 + 350	130 + 350	140 + 350	90 + 350	100 + 350			
		1k - 5 k	400 + 4000	500 + 4000	550 + 4000	600 + 4000	375 + 4000	400 + 4000			
		5k - 10 k	1300 + 8000	1400 + 8000	1500 + 8000	1600 + 8000	1200 + 8000	1200 + 8000			
		Hz	± (ppm output + μA)				± (ppm output + μA)				
220 mA	1 μA	10 - 20	550 + 4	600 + 4	650 + 4	700 + 4	375 + 4	400 + 4			
		20 - 40	280 + 3.5	310 + 3.5	330 + 3.5	350 + 3.5	220 + 3.5	250 + 3.5			
		40 - 1 k	100 + 3.5	120 + 3.5	130 + 3.5	140 + 3.5	90 + 3.5	100 + 3.5			
		1k - 5 k	400 + 40	500 + 40	550 + 40	600 + 40	375 + 40	400 + 40			
		5k - 10 k	1300 + 80	1400 + 80	1500 + 80	1600 + 80	1200 + 80	1200 + 80			
2.2 A	10 μA	20 - 1 k	500 + 35	550 + 35	600 + 35	650 + 35	500 + 35	550 + 35			
		1 k - 5 k	600 + 80	650 + 80	700 + 80	750 + 80	550 + 80	650 + 80			
		5 k - 10 k	6500 + 160	7500 + 160	8000 + 1600	8500 + 160	6000 + 160	7000 + 160			
5725A Amplifier:											
11 A	100 μA	40 - 1 k	370 + 170	400 + 170	440 + 170	460 + 170	300 + 170	330 + 170			
		1 k - 5 k	800 + 380	850 + 380	900 + 380	950 + 380	700 + 380	800 + 380			
		5 k - 10 k	3000 + 750	3300 + 750	3500 + 750	3600 + 750	2800 + 750	3200 + 750			

Note: Maximum output from the calibrator's terminals is 2.2 A. Uncertainty specifications for 220 μA and 2.2 mA ranges are increased by a factor of 1.3 plus 2 μA when supplied through 5725A terminals. Specifications are otherwise identical for all output locations.

Table 1-20. AC Current Secondary Performance Specifications and Operating Characteristics

Range	Frequency	Stability ±1 °C [Note 1]	Temperature Coefficient [Note 2]		Compliance Limits	Maximum Resistive Load For Full Accuracy [Note 3]	Noise and Distortion
		24 Hours	10°-40 °C	0°-10 °C and 40°-50 °C			Bandwidth 10 Hz-50 kHz <0.5V Burden
			Hz	± (ppm output + nA)			
220 μA	10 - 20	150 + 5	50 + 5	50 + 5	7	2k [Note 6]	0.05 + 0.1
	20 - 40	80 + 5	20 + 5	20 + 5			0.05 + 0.1
	40 - 1 k	30 + 3	4 + 0.5	10 + 0.5			0.05 + 0.1
	1k - 5 k	50 + 20	10 + 1	20 + 1			0.25 + 0.5
	5k - 10 k	400 + 100	20 + 100	20 + 100			0.5 + 1
2.2 mA	10 - 20	150 + 5	50 + 5	50 + 5	7	500	0.05 + 0.1
	20 - 40	80 + 5	20 + 4	20 + 4			0.05 + 0.1
	40 - 1 k	30 + 3	4 + 1	10 + 2			0.05 + 0.1
	1k - 5 k	50 + 20	10 + 100	20 + 100			0.25 + 0.5
	5k - 10 k	400 + 100	50 + 400	50 + 400			0.5 + 1
22 mA	10 - 20	150 + 50	50 + 10	50 + 10	7	150	0.05 + 0.1
	20 - 40	80 + 50	20 + 10	20 + 10			0.05 + 0.1
	40 - 1 k	30 + 30	4 + 10	10 + 20			0.05 + 0.1
	1k - 5 k	50 + 500	10 + 500	20 + 400			0.25 + 0.5
	5k - 10 k	400 + 1000	50 + 1000	50 + 1000			0.5 + 1
	Hz	± (ppm output + μA)	± (ppm output + μA)/°C				
220 mA	10 - 20	150 + 0.5	50 + 0.05	50 + 0.05	7	15	0.05 + 10
	20 - 40	80 + 0.5	20 + 0.05	20 + 0.05			0.05 + 10
	40 - 1 k	30 + 0.3	4 + 0.1	10 + 0.1			0.05 + 10
	1k - 5 k	50 + 3	10 + 2	20 + 2			0.25 + 50
	5k - 10 k	400 + 5	50 + 5	50 + 5			0.5 + 100
2.2 A	20 - 1 k	50 + 5	4 + 1	10 + 1	1.4 [Note 4]	0.5	0.5 + 100
	1 k - 5 k	80 + 20	10 + 5	20 + 5			0.3 + 500
	5 k - 10 k	800 + 50	50 + 10	50 + 10			1 + 1 mA
5725A Amplifier:							± (% output)
11 A	40 - 1 k	75 + 100	20 + 75	30 + 75	3	3	0.05
	1 k - 5 k	100 + 150	40 + 75	50 + 75			0.12
	5 k - 10 k	200 + 300	100 + 75	100 + 75			0.5
							[Note 5]

Notes:

Maximum output from 5720A terminals is 2.2 A. Uncertainty specifications for 220 μA and 2.2 mA ranges are increased by a factor of 1.3, plus 2 μA when supplied through 5725A terminals. Specifications are otherwise identical for all output locations.

1. Stability specifications are included in the Absolute Uncertainty values for the primary specifications.
2. Temperature coefficient is an adder to uncertainty specifications that does not apply unless operating more than ±5 °C from calibration temperature.

3. For larger resistive loads multiply uncertainty specifications by: $\left(\frac{\text{actual load}}{\text{maximum load for full accuracy}} \right)^2$

4. 1.5 V compliance limit above 1 A. 5725A Amplifier may be used in range-lock mode down to 1 A.

5. For resistive loads within rated compliance voltage limits.

6. For outputs from the Aux Current terminals, the maximum resistive load for full accuracy is 1 kΩ. For larger resistive loads, multiply the uncertainty as described in Note 3.

Minimum output: 9 μA for 220 μA range, 10 % on all other ranges. 1 A minimum for 5725A.

Inductive load limits: 400 μH (5700A/5720A, or 5725A). 20 μH for 5700A/5720A output >1 A.

Power factors: 5700A/5720A, 0.9 to 1; 5725A, 0.1 to 1. Subject to compliance voltage limits.

Frequency:

Range (Hz): 10.000-11.999, 12.00-119.99, 120.0-1199.9, 1.200 k-10.000 k

Uncertainty: ±0.01 %

Resolution: 11,999 counts

Settling time to full accuracy: 5 seconds for 5700A/5720A ranges; 6 seconds for 5725A 11 A range; +1 second for amplitude or frequency range change.

Overshoot: <10 %

1-17. Wideband AC Voltage (Option 5700-03) Specifications

Table 1-21. Wideband AC Voltage (Option 5700-03) Specifications

Specifications apply to the end of the cable and 50 Ω termination used for calibration

Range		Resolution	Absolute Uncertainty ±5 °C from calibration temperature 30 Hz-500 kHz			
			24 Hours	90 Days	180 Days	1 Year
Volts	dBm		± (% output + μV)			
1.1 mV	-46	10 nV	0.4 + 0.4	0.5 + 0.4	0.6 + 0.4	0.8 + 2
3 mV	-37	10 nV	0.4 + 1	0.45 + 1	0.5 + 1	0.7 + 3
11 mV	-26	100 nV	0.2 + 4	0.35 + 4	0.5 + 4	0.7 + 8
33 mV	-17	100 nV	0.2 + 10	0.3 + 10	0.45 + 10	0.6 + 16
110 mV	-6.2	1 μV	0.2 + 40	0.3 + 40	0.45 + 40	0.6 + 40
330 mV	+3.4	1 μV	0.2 + 100	2.5 + 100	0.35 + 100	0.5 + 100
1.1 V	+14	10 μV	0.2 + 400	0.25 + 400	0.35 + 400	0.5 + 400
3.5 V	+24	10 μV	0.15 + 500	0.2 + 500	0.3 + 500	0.4 + 500

Frequency	Frequency Resolution	Amplitude Flatness, 1 kHz Reference Voltage Range			Temperature Coefficient	Settling Time To Full Accuracy	Harmonic Distortion
		1.1 mV	3 mV	>3 mV			
Hz	Hz	± (% output + floor indicated)			±ppm/°C	Seconds	dB
10 - 30	0.01	0.3	0.3	0.3	100	7	-40
30 - 120	0.01	0.1	0.1	0.1	100	7	-40
120 - 1.2 k	0.1	0.1	0.1	0.1	100	5	-40
1.2 k - 12 k	1	0.1	0.1	0.1	100	5	-40
12 k - 120 k	10	0.1	0.1	0.1	100	5	-40
120 k - 1.2 M	100	0.2 + 3 μV	0.1 + 3 μV	0.1 + 3 μV	100	5	-40
1.2 M - 2 M	100 k	0.2 + 3 μV	0.1 + 3 μV	0.1 + 3 μV	100	0.5	-40
2 M - 10 M	100 k	0.4 + 3 μV	0.3 + 3 μV	0.2 + 3 μV	100	0.5	-40
10 M - 20 M	1 M	0.6 + 3 μV	0.5 + 3 μV	0.4 + 3 μV	150	0.5	-34
20 M - 30 M	1 M	10.5 + 15 μV	10.5 + 3 μV	1 + 3 μV	300	0.5	-34

Additional Operating Information:

dBm reference = 50 Ω

Range boundaries are at voltage points, dBm levels are approximate.

$dBm = 10 \log \left(\frac{\text{Power}}{1 \text{ mW}} \right)$; 0.22361 V across 50 Ω = 1 mW or 0 dBm

Minimum output: 300 μV (-57 dBm)

Frequency uncertainty: ±0.01 %

Frequency resolution: 11,999 counts to 1.1999 MHz, 119 counts to 30 MHz.

Overload protection: A short circuit on the wideband output will not result in damage. After settling time, normal operation is restored upon removal.

1-18. General Specifications

Warm-Up Time: Twice the time since last warmed up, to a maximum of 30 minutes.

System installation: Rear output configuration and rack-mount kit available.

Standard interfaces: IEEE-488, RS-232, 5725A, 5205A or 5215A, 5220A, phase lock in (BNC), phase reference out (BNC).

Temperature performance: Operating: 0 °C to 50 °C. Calibration: 15 °C to 35 °C. Storage: -40 °C to 75 °C; DC Zeros calibration required every 30 days.

Relative humidity: Operating: <80 % to 30 °C, <70 % to 40 °C, <40 % to 50 °C. Storage: <95 %, non-condensing. A power stabilization period of four days may be required after extended storage at high temperature and humidity.

Safety: Designed to comply with UL3111; EN61010; CSA C22.2 No. 1010; ANSI/ISA S82.01-1994

Guard isolation: 20 V

EMI/RFI: Designed to comply with FCC Rules Part 15, Subpart B, Class B; EN50081-1, EN50082-1

Electro Static Discharge: This instrument meets criteria C for ESD requirements per EN61326

Line Power: 47 to 63 Hz; ± 10 % allowed about selectable nominal line voltage: 100 V, 110 V, 115 V, 120 V, 200 V, 220 V, 230 V, 240 V. Maximum power: 5700A/5720A, 300 VA; 5725A, 750 VA.

Size:

5700A/5720A: Height 17.8 cm (7 in), standard rack increment, plus 1.5 cm (0.6 in) for feet; Width 43.2 cm (17 in), standard rack width; Depth 63.0 cm (24.8 in), overall; 57.8 cm (22.7 in), rack depth.

5725A: Height 13.3 cm, (5.25 in); Width and depth same as 5700A/5720A. Both units project 5.1 cm, (2 in) from rack front.

Weight: 5700A/5720A: 27kg (62 lbs); 5725A: 32kg (70 lbs).

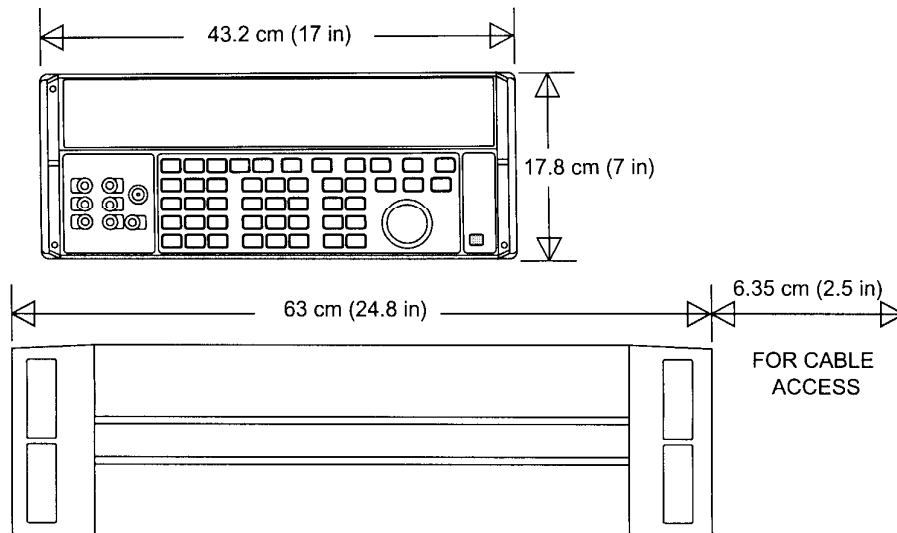

1-19. Auxiliary Amplifier Specifications

For complete specifications, see the 5205A and 5220A Operators Manuals.

5205A (220V - 1100 V ac, 0 V - 1100 V dc)

Overshoot: < 10 %

Distortion (bandwidth 10 Hz - 1 MHz):

10 Hz - 20 kHz	0.07 %
20 kHz - 50 kHz	0.2 %
50 kHz - 100 kHz	0.25 %

Frequency (Hz)	90 Day Accuracy at 23° ±5 °C ± (% output + % range)	Temperature Coefficient for 0°-18 °C and 28°-50 °C ± (ppm output + ppm range)/ °C
dc	0.05 + 0.005	15 + 3
10 - 40	0.15 + 0.005	45 + 3
40 - 20 k	0.04 + 0.004	15 + 3
20 k - 50 k	0.08 + 0.006	50 + 10
50 k - 100 k	0.1 + 0.01	70 + 20

5220A (AC Current, 180-day specifications):

Accuracy:

20 Hz - 1 kHz	0.07% + 1 mA
1 kHz - 5 kHz	(0.07% + 1mA) x frequency in kHz

Temperature Coefficient (0° - 18 °C and 28° - 50 °C): (0.003 % + 100 μA)/°C

Distortion (bandwidth 300 kHz):

20 Hz - 1 kHz	0.1% + 1 mA
1 kHz - 5 kHz	(0.1% + 1 mA) x frequency in kHz

Note: 5700A/5720A combined with 5220A is not specified for inductive loads.

Chapter 2

Installation

	Title	Page
2-1.	Introduction	2-3
2-2.	Unpacking and Inspection	2-3
2-3.	Service Information	2-5
2-4.	Placement and Rack Mounting.....	2-5
2-5.	Cooling Considerations	2-5
2-6.	Connecting to the 5700A Calibrator	2-6
2-7.	Selecting Line Voltage	2-7
2-8.	Accessing the Fuse	2-8
2-9.	Connecting to Line Power.....	2-9